

---

# 100W SPOT + 4X10W WASH

Professional Stage Lighting Manufacturer

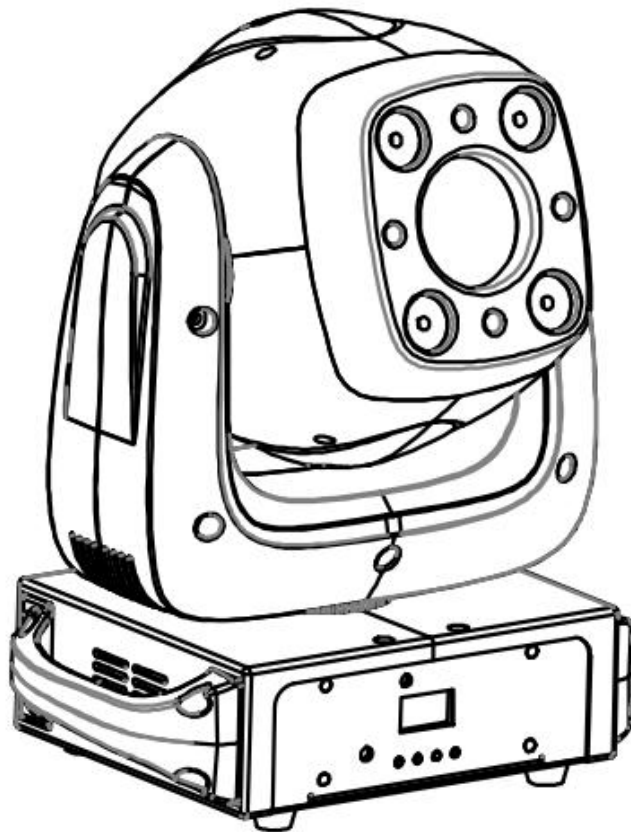

User Manual



---

## **Operational Manual**

Thank you for purchasing this product. To take full advantage of all possibilities and for your own safety, please read this operating instructions very carefully before you start using this unit.

### **BEFORE USE**

- Before you start using this unit, please check if there is no transportation damage. Should there be any, do not use the device and consult your dealer first.
- This device has left our factory in absolutely perfect condition and well packed. In order to maintain this condition and to ensure a safe operation, it is absolutely necessary for the user to follow the safety instructions and warning notes written in this manual.
- The manufacturer will not accept liability for any resulting damages caused by the non-observance of this manual or any unauthorized modification to the device.
- Please consider that damages caused by manual modifications to the device are not subject to warranty.

### **SAFETY INSTRUCTIONS**

**DANGEROUS VOLTAGE CONSTITUTING A RISK OF ELECTRIC SHOCK IS PRESENT WITHIN THIS UNIT!**

**Caution:** To reduce the risk of electric shock, do not remove the top cover. No user-serviceable parts inside. Refer servicing to qualified service personnel only.



Risk of electric shot!



Keep this device away from rain and moisture!



Read the manual



Unplug the mains power before remove the housing



Indoor use ONLY

---

**Caution:** Do not stare at operating lamp. May be harmful to the eye.

- To protect the environment, please try to recycle the packing material as much as possible.
- To prevent fire or shock hazard, do not expose this appliance to rain or moisture.
- This unit is for indoor use only.
- Don't place metal objects or spill liquid inside the unit. Electric shock or malfunction may result. If a foreign object enters the unit, immediately disconnect the mains power.
- Locate the fixture in a well ventilated spot, away from any flammable materials and/or liquids. The fixture must be fixed at least 50cm from surrounding walls.
- Don't cover any ventilation openings as this may result in overheating.
- Prevent use in dusty environments and clean the unit regularly.
- Keep the unit away from children.
- Inexperienced persons should not operate this device.
- Maximum safe ambient temperature is 40 °C. Don't use this unit at higher ambient temperatures.
- Make sure the area below the installation place is free from unwanted persons during rigging, de-rigging and servicing.
- Allow the device about 10 minutes to cool down before servicing.
- The electrical installation should be carried out by qualified person only, according to the regulations for electric and mechanical safety in your country.
- Check that the available voltage is not higher than the one stated in the unit.
- The power cord should always be in perfect condition. Switch the unit immediately off when the power cord is squashed or damaged. It must be replaced by the manufacturer, its service agent or similarly qualified persons in order to avoid a hazard.
- Never let the power-cord come into contact with other cables!
- Don't connect the unit to any dimer pack.
- In order to prevent electric shock, do not open the cover. There are no user serviceable parts inside.
- The housing and lenses must be replaced if they are visibly damaged.
- Never repair a fuse or bypass the fuse holder. Always replace a damaged fuse with a fuse of the same type and electrical specifications!
- Due to safety reasons, it is prohibited to make unauthorized modifications to the unit.

**Important: Never look directly into the light source! Don't use the effect in the presence of persons suffering from epilepsy.**

## Mounting and Installation

**Important: Fixtures must be installed by a Qualified electrician in accordance with all national and local electrical and construction codes and regulations.**

## Overhead Rigging

- For overhead installation, the fixture must be always secured with a safety wire that can bear at least 10 times the weight of the fixture.
- Make sure the area below the installation is free from unwanted persons during rigging, de-rigging and servicing.
- Locate the fixture in a well ventilated spot, far away from any flammable materials and/or liquids. The fixture must be fixed at least 50cm from surrounding walls.
- The device must be installed out of reach of people in outside areas where persons may walk by or be seated.
- Fixture installation must always be secured with a secondary safety attachment, such as an appropriate safety cable.
- Always use and install the supplied safety cable as a safe cable as a safety measure to prevent accidental damage and /or injury in the event the clamp fails.
- The fixture should be well fixed, a free-swinging mounting is dangerous and may not be considered!

## Clamp Mounting :

The LED moving head provides a unique mounting bracket assembly that integrates the bottom of the base, the included 'omega bracket' (see the following pic) and the safety cable rigging point in one unit. When mounting this fixture to truss be sure to secure an appropriately rated clamp to the included omega bracket using a M10 screw fitted through the center hole of the 'omega bracket'. As an added safety measure be sure to attach at least one properly rated safety cable to the fixture using one of the safety cable rigging points integrated in the base assembly.

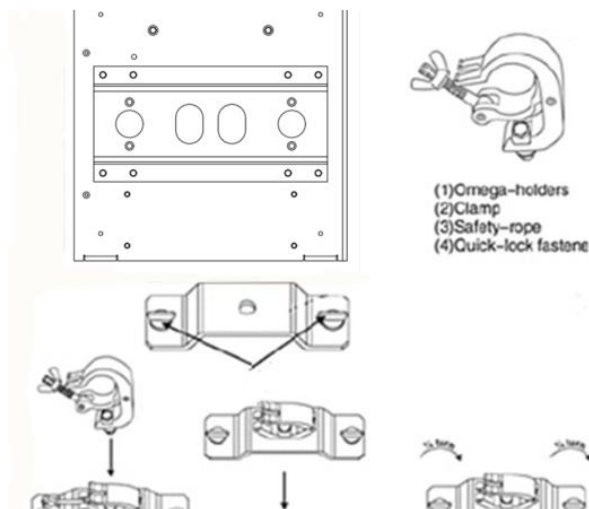



## DMX-512 Control Connection

Connect the provided XLR cable to the female 3-pin XLR output of your controller and the other side to the male 3-pin XLR input of the moving head. You can chain multiple Moving head together through serial linking. The cable needed should be two core, screened cable with XLR input and output connectors. Please refer to the diagram below.

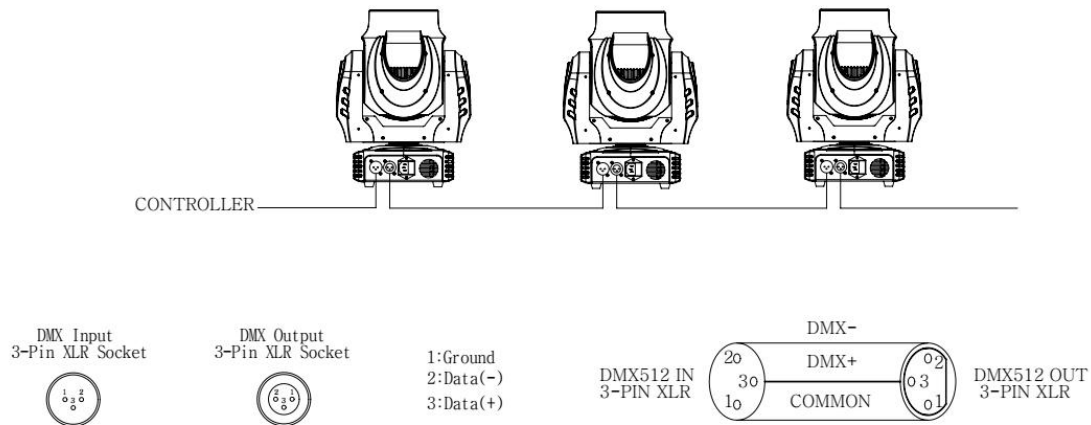

## DMX-512 Connection with DMX Terminator

For installations where the DMX cable has to run a long distance or is in an electrically noisy environment, such as in a discotheque, it is recommended to use a DMX terminator. This helps in preventing corruption of the digital control signal by electrical noise. The DMX terminator is simply an XLR plug with a 120 resistor connected between pins 2 and 3, which is then plugged into the output XLR socket of the last fixture in the chain. Please see illustrations below.

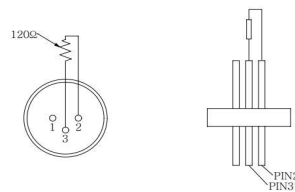

## How to Set up this Unit

1. [MIC]: micro phone for sound mode
2. [MENU]: press this button to go back to the main menu or to leave sub-menu
3. [▼]:press this button to go down in the menu
4. [▲]:press this button to go up in the menu
5. [Enter]:press this button to confirm the selected function in the menu
6. [Display]:shows the information on the different modes and functions
7. [SOUND SENSITIVITY CONTROL]:To adjust the sensitivity of the sound mode
8. [NETWORK INTERFACE]: DMX512 network interface(Optional)

- 
9. [DMX IN]:3p XLR Male connector to receive DMX data from a console or use in Master/slave modes
  10. [DMX OUT]:3 pin XLR Female connector to connect other projectors or use in Master/slave modes
  11. [USB WIRELESS TRANSCIEVER SOCKET]:USB wireless transceiver,with 5v power supply (Optional)
  12. [POWER IN]:with IEC socket and integrated fuse holder,connect the supplied mains cable here
  13. [FUSE]:Protecting the safety operation of circuit
  14. [FAN]:for cooling the electronic components in the base of the machine

## **Technical Specifications**

Input power:AC100-240V 50/60 Hz

Power consumption:170w

Power connection:10A

Connection:3pin-XLR male/female

Extremely Long Life:50,000 Hr and low power consumption

Light Source spot:100W White LED

Light Source wash: 4x 10W RGBW LED

Focus: Motorized focus

Zoom angle: 18 degree

Prism: 3-face

DMX channel:12/16/23 channels

Gobo1: 7+1

Gobo2: 8+1

Gobo functions: Gobo-Flow effect, Gobo shake

Rotation: Bi-directional

Colors: 7 +1

Color functions: Rainbow-flow effect

Movement:Pan/Tilt:X axis 540°, Y axis 190°

High speed of pan/tilt movement, speed of pan/tilt movement is adjustable

Control mode:DMX512/Master-Slave/Auto run/sound

Display: OLED display

8 internal program , sound mode can control by DXM 512

IP-Rating:IP20

N.W: 7.3 KG

G.W: 8.4 KG

Packing size : 39.5\*32.5\*29cm

## Dimensions

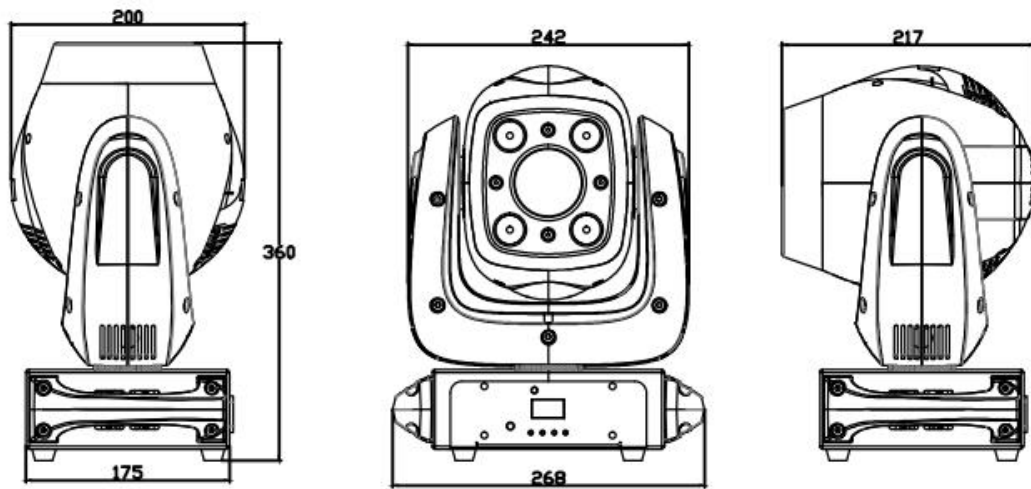

## Menu Function

<b>1.DMX Address</b>	001-512		
<b>2.DMX Channel</b>	DMX 23 Ch		
	DMX 16 Ch		
	DMX 12 Ch		
<b>3.Running Mode</b>	DMX		
	Auto		
	Sound		
	Slave		
<b>4.Programs</b>	Program1		
	Program2		
	Program3		
	Program4		
	Program5		
	Program6		
	Program7		
	Program8		
<b>5.Settings</b>	Pan Rev	No	
		Yes	
	Tilt Rev	No	
		Yes	
	Display Rev	No	
		Yes	

	Sensitivity	0-100	
	Dmx Fail	OFF	
		Hold	
	Calibration	Password	
		All To Origin	Clear ALL(3s)
		Pan	.=-127~128
		Tilt	.=-127~128
		Red	.=0~255
		Green	.=0~255
		Blue	.=0~255
		Spot Color	.=-127~128
		Fixed Gobo	.=-127~128
		Wheel Gobo	.=-127~128
		Focus	.=-127~128
		Prism	.=-127~128
		Factory Reset	Yes
	No		
	Reset Motor	(Reset all Motor)	
	6.System Info	Soft verb	
		Mode	DMX
Address		001	

## DMX- Configuration

### 12 Channel Mode:

12CH	DMX Value	Function
1	000-255	Pan
2	000-255	Tilt
3	000-255	Dimmer spot
4	000-009	Strobe open spot
	010-250	Strobe from slow to fast spot
	251-255	Strobe open spot
5	000-255	Focus
6	000-255	Dimmer wash
7	000-009	Strobe open wash
	010-250	Strobe from slow to fast wash
	251-255	Strobe open wash
8	000-255	Color temperature
9	000-010	No function
	011-020	R

	021-030	G
	031-040	B
	041-050	W
	051-060	R+W
	061-070	G+W
	071-080	B+W
	081-090	R+G
	091-100	G+B
	101-110	R+B
	111-120	R+G+W
	121-130	G+B+W
	131-140	R+B+W
	141-150	R+G+B+W
	151-200	Color step program increasing from slow to fast
201-255	Color fade program increasing from slow to fast	
10	000-024	No function
	025-050	Auto play 1
	051-075	Auto play 2
	076-100	Auto play 3
	101-125	Auto play 4
	126-150	Auto play 5
	151-175	Auto play 6
	176-200	Auto play 7
	201-255	Color Gobo increasing sound sensitivity
11	000-010	No function
	011-020	program 1
	021-030	program 2
	031-040	program 3
	041-050	program 4
	051-060	program 5
	061-070	program 6
	071-080	program 7
	081-090	program 8
	091-230	Sound active sensitivity from min to max increasing
	231-255	No function
	12	000-229
230-240		Reset after 3 seconds
241-255		No function

**16 and 23 Channel Mode:**

16CH	23CH	DMX Value	Function
1	1	000-255	Pan
	2	000-255	Pan fine
2	3	000-255	Tilt
	4	000-255	Tilt fine
	5	000-255	P/T Speed
3	6	000-255	Dimmer spot
4	7	000-009	Strobe open spot
		010-250	Strobe from slow to fast spot
		251-255	Strobe open spot
5	8	000-004	Open(White)
		005-013	White/Color1
		014-022	Color1
		023-031	Color1/Color2
		032-040	Color2
		041-049	Color2/Color3
		050-058	Color3
		059-067	Color3/Color4
		068-076	Color4
		077-085	Color4/Color5
		086-094	Color5
		095-103	Color5/Color6
		104-112	Color6
		113-121	Color6/Color7
		122-130	Color7
		131-139	Open(White)
140-195	Forward rainbow effect from fast to slow		
196-199	Rotation stop		
	200-255	Backward rainbow effect from slow to fast	
6	9	000-007	open(Fixed Gobo)
		008-015	Gobo 1
		016-023	Gobo 2
		024-031	Gobo 3
		032-039	Gobo 4

		040-047	Gobo 5
		048-055	Gobo 6
		056-063	Gobo 7
		064-077	Gobo 8
		078-085	Gobo 1 Shake fast to slow
		086-093	Gobo 2 Shake fast to slow
		094-101	Gobo 3 Shake fast to slow
		102-109	Gobo 4 Shake fast to slow
		110-117	Gobo 5 Shake fast to slow
		118-125	Gobo 6 Shake fast to slow
		126-133	Gobo 7 Shake fast to slow
		134-147	Gobo 8 Shake fast to slow
		148-199	Forward rainbow effect from fast to slow
		200-203	Rotation stop
		204-255	Backward rainbow effect from slow to fast
7	10	000-007	Open(Wheel Gobo2)
		008-017	Gobo1
		018-027	Gobo2
		028-037	Gobo3
		038-047	Gobo4
		048-057	Gobo5
		058-067	Gobo6
		068-077	Gobo7
		078-087	Gobo1 Shake
		088-097	Gobo2 Shake
		098-107	Gobo3 Shake
		108-117	Gobo4 Shake
		118-127	Gobo5 Shake
		128-137	Gobo6 Shake
		138-147	Gobo7 Shake
		148-199	Forward rainbow effect from fast to slow
		200-203	Rotation stop
204-255	Backward rainbow effect from slow to fast		
8	11	000-007	Stop
		008-129	Forward Gobo2 Rotation from slow to fast
		130-133	Stop
		134-255	Backward Gobo2 Rotation from fast to slow
9	12	000-255	Focus
10	13	000-007	Open(White)

		008-130	Prism
		131-255	Forward Prism Rotation from slow to fast
11	14	000-255	Dimmer wash
12	15	000-009	Strobe open wash
		010-250	Strobe from slow to fast wash
		251-255	Strobe open wash
13	16	000-255	Red
14	17	000-255	Green
15	18	000-255	Blue
16	19	000-255	White
	20	000-255	Color temperature
	21	000-010	No function
		011-020	R
		021-030	G
		031-040	B
		041-050	W
		051-060	R+W
		061-070	G+W
		071-080	B+W
		081-090	R+G
		091-100	G+B
		101-110	R+B
		111-120	R+G+W
		121-130	G+B+W
		131-140	R+B+W
		141-150	R+G+B+W
		151-200	Color step program increasing from slow to fast
		201-255	Color fade program increasing from slow to fast
	22	000-024	No function
		025-050	Auto play 1
		051-075	Auto play 2
		076-100	Auto play 3
		101-125	Auto play 4
		126-150	Auto play 5
		151-175	Auto play 6
		176-200	Auto play 7
		201-255	Color Gobo increasing sound sensitivity
	23	000-010	No function
		011-020	program 1



	021-030	program 2
	031-040	program 3
	041-050	program 4
	051-060	program 5
	061-070	program 6
	071-080	program 7
	081-090	program 8
	091-230	Sound active sensitivity from min to max increasing
	230-240	Reset after 3 seconds
	240-255	No function

## Maintenance

### **DANGER !**

**Disconnect from the mains before starting any maintenance work.**

- Make sure the area below is free from any unwanted persons during servicing.
- Switch off the unit, unplug the mains cable and wait until the unit is cool down.

### **During inspection the following points should be checked:**

- All screws used for installing the device and any of its parts should be tightly fastened and may not be corroded.
- Housing, fixations and installation spots (ceiling, truss, suspensions) should be totally free from any deformation.
- When an optical lens is visibly damaged due to cracks or deep scratches, it must be replaced.
- The mains cables must be in impeccable condition and should be replaced immediately when even a small problem is detected.
- In order to protect the device from overheating, the cooling fans (if any) and ventilation opening should be cleaned monthly.
- The interior of the device should be cleaned annually using a vacuum cleaner or air-jet.
- The cleaning of internal and external optical lenses and/or mirrors must be carried out periodically to optimize light output. Cleaning frequency depends on the environment in which the fixture operates: damp, smoky or particularly dirty surroundings can cause greater accumulation of dirt on the unit's optics.
- Clean with a soft cloth using normal glass cleaning products.
- Always dry the parts carefully.
- Clean the external optics at least every 30 days.
- Clean the internal optics at least every 90 days.

**Important: we strongly recommend internal cleaning to be carried out by qualified**

---

**personnel!**